



Danger! Never carry out work on live parts!
Danger of fatal injury!
The product must not be used in case of obvious damage!
To be installed by an authorized person only!

- The full operation manual is available at: http://www.tele-online.com/resources/data-sheets/en_na003.pdf
- This Quick Start Guide does not replace the manual and the owner should read in conjunction with the whole Manual.
- The safety instructions are to be observed

Intended use:

The TELE NA003-M64 is a multinational grid and system protection unit, that protects energy generation plants (like combined heat and power plants, wind generators, waterpower plants, photovoltaic plants). In case of power failures or net anomalies, power generating plants have to be disconnected immediately from the mains supply to avoid unintentional feeding to the grid. On the one hand continuing grid feeding could endanger maintenance staffs, on the other hand connected devices could be exposed to inadmissible voltages and/or frequencies.

In case the grid operator requires thresholds and settings that are not conforming with the local standards, it is possible to set thresholds outside the normative defined range! Outside these range the device is not in accordance with the standards anymore and the corresponding certificate loses validity! This state is indicated as „ncnF“ [none conformity] on the display. Settings outside the conformity range are therefore in responsibility of the operator respectively the acceptance authority!

Safety advice:

The device was developed, produced and tested in accordance to the latest industry standards. Nevertheless improper handling or use can endanger humans and machines.

Please use the device only in accordance with the installation and operating instructions. Check for secure assembly and good condition. Moreover, the rules and regulations on accident prevention applicable to the place of use must be strictly followed.

- Eliminate all faults immediately which may endanger safety!
- Do not make any unauthorised changes and only use replacement parts and optional accessories purchased from or recommended by TELE!
- In case of obvious damage the device must be checked and replaced if necessary!
- Country specific regulations have to be considered in any case!
- If required by national standards, the NA003 has to be protected against unauthorized changes by password and/or sealing!

Mounting on DIN rail according to EN 60715:

Snap the rear mounting clip of the device into place in such a way that a safe and tight fit is ensured.

Available configurations/Local standards:

CEI 0-21:2019, VDE 0126-1-1:2013, VDE 0124-100:2013, VDE 4105:2018 <50kW, VDE 4105:2018 >50kW, VDE 4105:2018 Umr, G59/3/3:2015 LV, G99/1/3:2018 LV, G59/3/3:2015 MV, G99/1/3:2018 HV, G83/2:2012, G98/1/2:2018, C10-11:2012 LV, C10-11:2019 LV-IP, C10-11:2019 LV-ASS, C10-11:2012 MV, C10-11:2019 HV-IP, C10-11:2019 HV-ASS, TR3 Rev23:2013, VDE 4110:2018 TR3-25, OVE E 8001/8101:2014, OVE TOR R25 NS SYNC, OVE TOR R25 NS ASYNC, OVE TOR R25 MS SYNC, OVE TOR R25 MS ASYNC, EN50438:2013, EN50438:2013 DK, NRS 097-2-1:2017, OPEN SETUP

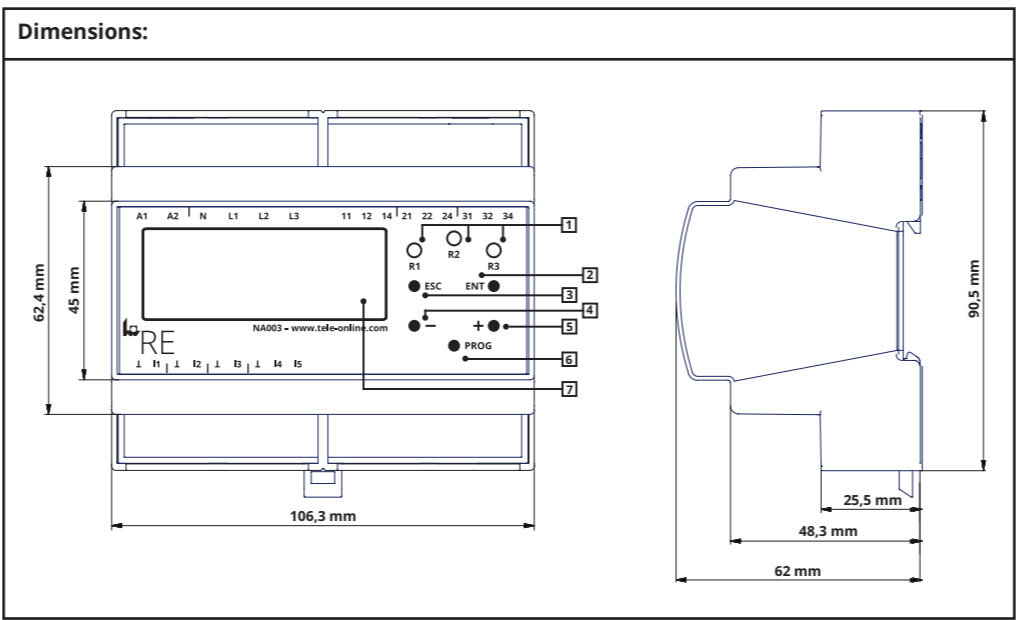

Controls elements:

Legend	Marking	Type	Function
1	R1, R2, R3	LED (yellow)	Status indication output relays
2	ENT	Pushbutton	ENTER, Input confirmation, menu level forward
3	ESC	Pushbutton	ESCAPE, Input rejection, menu level back, test/reset
4	-	Pushbutton	Change parameters, menu navigation
5	+	Pushbutton	Change parameters, menu navigation
6	PROG	Pushbutton (sealable)	PROGRAM, enter program mode
7		LCD-Display 4x20 characters	Display

Terminals:

Terminal	Description	Specifications
A1, A2	Supply	DC: 24V AC: 110 - 230V @ f: 48-63 Hz A1: L (+) A2: N (-)
L1, L2, L3, N	Measuring input	U _N : 3x400V AC
11, 12, 14	Relay channel A (CO contact) Status indication via yellow LED R1	Isolated changeover contact 11: Common 12: Normally closed contact 14: Normally open contact
21, 22, 24	Relay channel B (CO contact) Status indication via yellow LED R2	Isolated changeover contact 21: Common 22: Normally closed contact 24: Normally open contact
31, 32, 34	Relay channel D (CO contact) Status indication via yellow LED R3	Isolated changeover contact 31: Common 32: Normally closed contact 34: Normally open contact
11, ⊥	Digital input 1 (Feedback contact contactor A)	Contact input (24V/5mA) Input active: I1 connected to ⊥
12, ⊥	Digital input 2 (Feedback contact contactor B)	Contact input (24V/5mA) Input active: I2 connected to ⊥ Does not apply to national standards without functional safety!
13, ⊥	Digital input 3 (Remote disconnection)	Contact input (24V/5mA) Input active: I3 connected to ⊥
14, 15, ⊥	Digital inputs 4 und 5 (Parameter switchover)	Applies to CEI 0-21 Contact input (24V/5mA) Input active: I4 or I5 connected to ⊥

Technical data:

Supply circuit
Supply voltage: DC: 24V AC: 110 - 230V
Supply voltage tolerance: DC: ± 10% AC: ± 30%
Nominal consumption: max. 1,25W / 4VA @ 230V AC
Rated frequency: 50 / 60Hz
Tolerance of rated frequency: 48 - 63Hz
Rated surge voltage: 6 kV
Internal protection: 250V / 500mA slow blow (soldered)

In order to ensure the proper function during power failures, an external UPS has to be used.

Measuring circuit
Measuring input: 3 x 400V AC
Input impedance: 1MΩ
Measurand: line to line voltage, line to neutral voltage, 10 minutes average voltage, frequency, rate of change of frequency (RoCoF), phase shift (PShift)

Measuring ranges
Line to line voltage: 0 - 560VAC
Line to neutral voltage: 0 - 325VAC
Frequency: 40 - 65Hz
RoCoF: 100mHz/s ... 2.000mHz/s
Pshift: 1 - 15°
Overload capacity: Permanent 1,4 x U_{Nom} Pulse 1,6 x U_{Nom} (1 second)
Overvoltage category: III
Rated surge voltage: 4 kV

Digital inputs
Type of contact: potential free
Min. switching voltage/ switching current: 24V DC / 5mA

Output circuit
Number of contacts: 3 changeover contacts
Contact material: AgNi
Rated current: 5A / 250V AC
Electrical endurance: 100 x 10³ switching cycles (AC-1)
Mechanical endurance: 15 x 10⁶ switching cycles
Continuous current value: 5A
Short time value (1s): 5A
Withstanding voltage across open contacts: Relay contacts: 1000V_{rms} Terminals: 450V_{rms}
Overvoltage category: III
Rated surge voltage: 4 kV
Protection: 5A fast blow

Accuracy
Voltage monitoring:
Base accuracy: < 0,5% @ +25°C
Temperature influence: < 0,01% / °C
Resolution: 10mV
Frequency monitoring:
Base accuracy: < 0,01Hz @ +25°C
Temperature influence: < 0,0002Hz / °C
Resolution: 1mHz

Isolation data
Rated insulation voltage: 400V
Supply circuit / Measuring circuit: protective insulation
Supply circuit / Output circuit: protective insulation
Supply circuit / Digital inputs: protective insulation
Output circuit / Measuring circuit: basic insulation
Output circuit / Digital inputs: basic insulation

Environmental conditions
Ambient temperature operation: -25 ... +55°C
Ambient temperature storage: -40 ... +70°C
Visibility temperature display: -15 ... +55°C
Relative humidity: 5 ... 95% (non-condensing)
Degree of contamination: 2
Weight: 300g

Electrical connection
Wire size: max. 2,5mm²
Stripping length: max. 8mm
Electrical strength: max. 450V/16A (digital inputs; relay outputs)
max. 750V/16A (measuring inputs)
Torque: max. 0,5Nm
Screw: M3, slot screwdriver 0,6 x 3,5mm

Protection class
Terminals: IP20 Housing: IP20

Connection diagram 1:

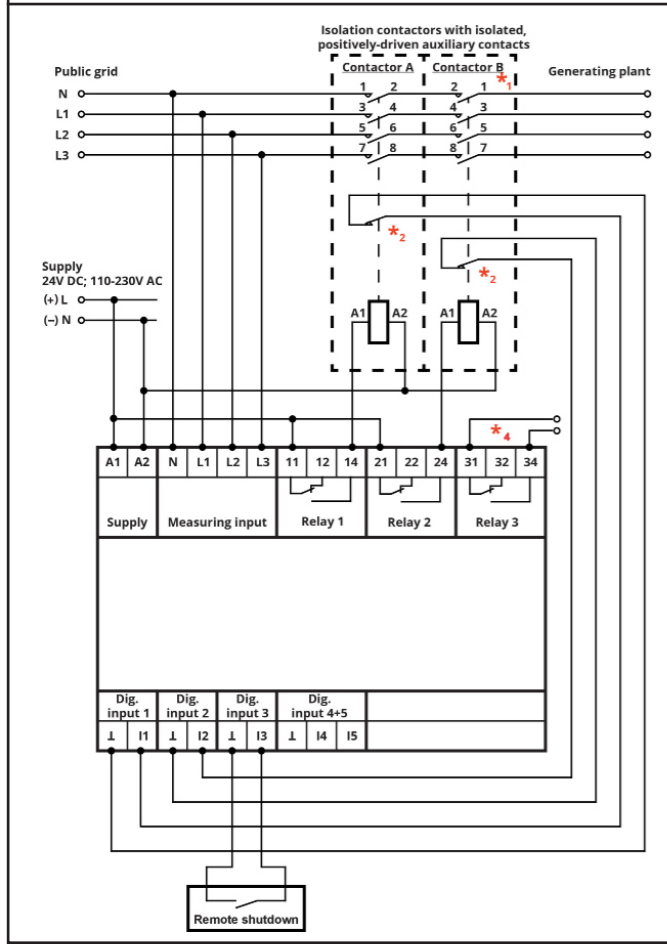

Applies to:

- » VDE 0126-1-1:2013
 - » VDE 0124-100:2013
 - » *1,*4 VDE 4105:2018 >50kW, VDE 4105:2018 <50kW,
 - » *4 VDE 4105:2018 Umr,
 - » *1 VDE 4110:2018 TR3-25
 - » *1 G99/1/3:2018 LV, G99/1/3:2018 HV, G98/1/2:2018, G59/3/3:2015 LV, G59/3/3:2015 MV, G83/2:2012
 - » *1,*4 C10-11:2019 LV-IP, C10-11:2019 LV-ASS, C10-11:2019 HV-IP, C10-11:2019 HV-ASS
 - » *1 C10-11:2012 LV, C10-11:2012 MV
 - » TR3 Rev23:2013
 - » OVE TOR R25 NS SYNC, OVE TOR R25 NS ASYNC, OVE TOR R25 MS SYNC, OVE TOR R25 MS ASYNC, OVE E 8001/8101:2014
 - » *3 EN50438:2013, EN50438:2013 DK
 - » NRS 097-2-1:2017
 - » OPEN SETUP
- *1 ... Contactor B is not necessary for applications requiring no functional safety Auxiliary contact configurable as "normally open", "normally closed" or "disabled"
- *2 ... 1- or 2-channel connection possible and can be configured
- *3 ... Error energy generation plants conforming VDE-AR-N 4105:2018-11 (Pn ≤ 50 kW) VDE-AR-N 4105:2018-11 (Pn > 50 kW) VDE-AR-N 4105:2018-11 (Inverter) C10-11 LV:2019 C10-11 HV:2019

Menu structure:

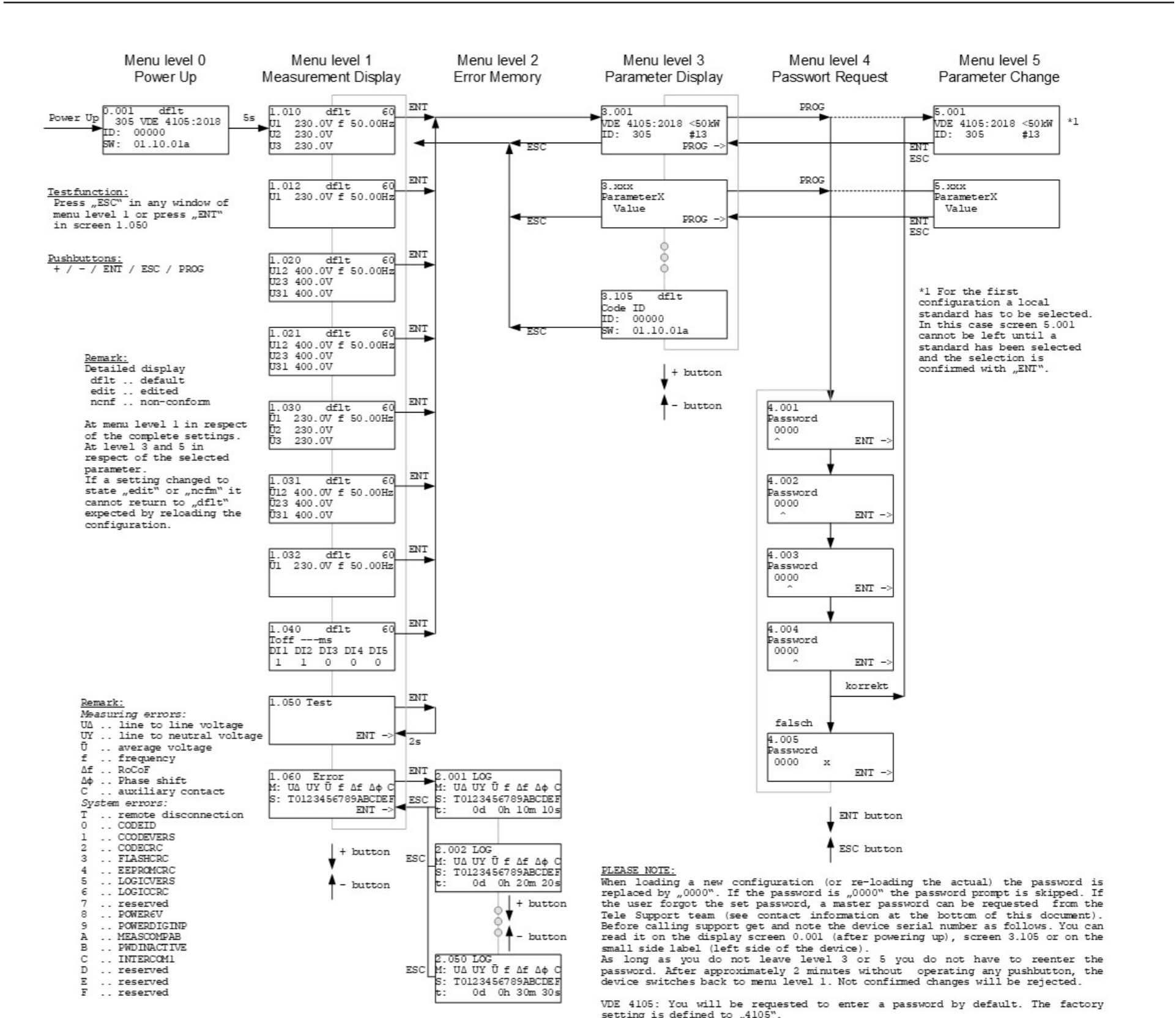

Connection diagram 2:

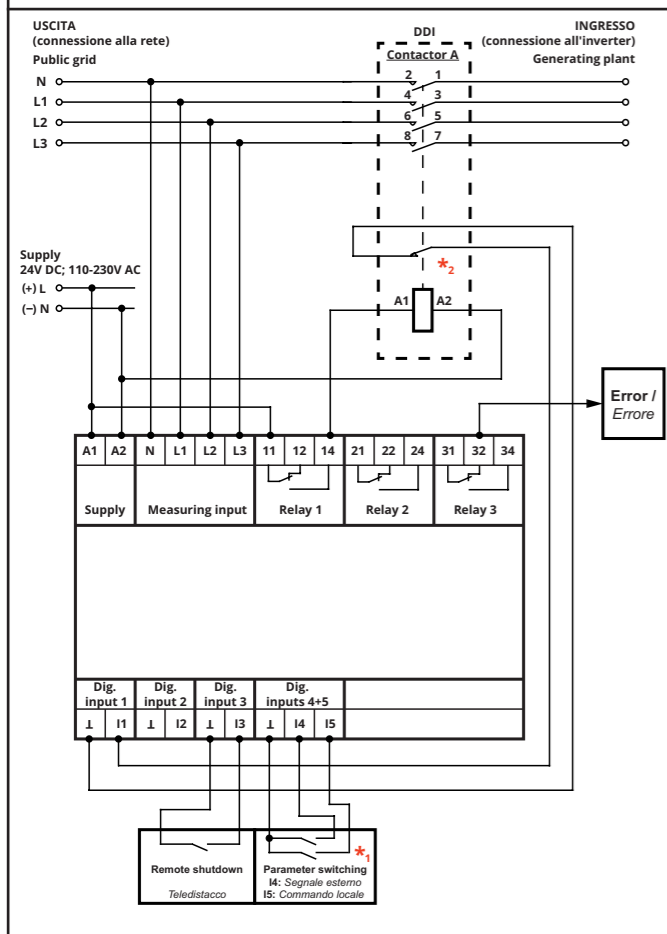

Applies to:

- » CEI 0-21:2019
- *1 ... Parameter switching:
- **definitive mode (Operational mode 0):**
I4 inactive / contact opened:
overfrequency 1, underfrequency 1
I4 active / contact closed:
overfrequency 2, underfrequency 2
 - **transitory mode (Operational mode 1):**
I5 active / contact closed:
overfrequency 2, underfrequency 2
I5 inactive / contact open:
overfrequency 3, underfrequency 3
- *2 ... Auxiliary contact configurable as "normally open", "normally closed" or "disabled"

TELE Haase Steuergeraete Ges.m.b.H.
Vorarlberger Allee 38
AT-1230 Vienna
Austria

NEED SUPPORT PLEASE
CALL: +43 / 1 / 614 74-0 (CET working hours)
E-MAIL: support@tele-haase.at

Subject to alterations and errors.
Release 05/2020